

A - A

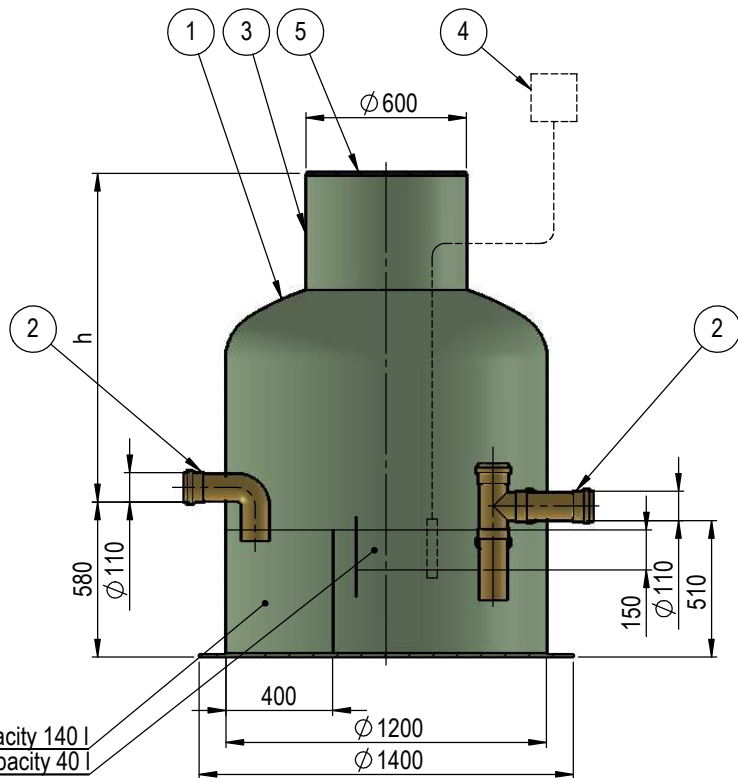

Sediment capacity 140 l
Grease layer capacity 40 l

B - B

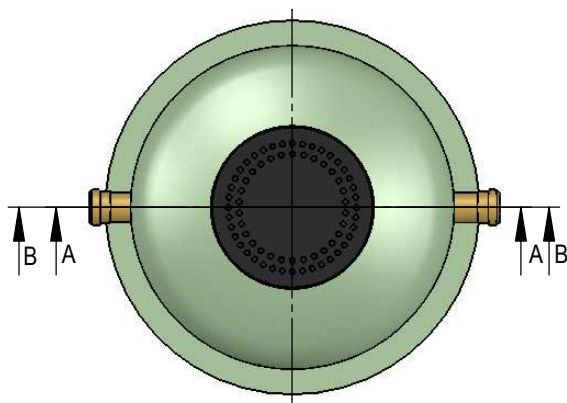
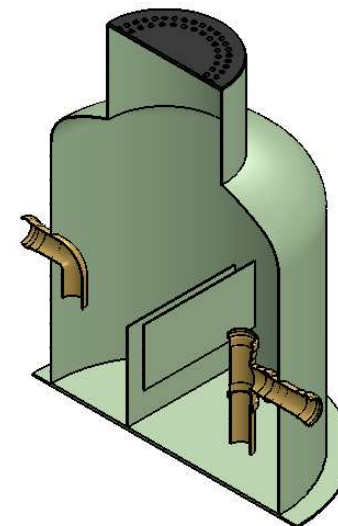

Separator max. flow: 1 l/s
h = height as needed 900 ... 2500 (mark to table)

Item no.	Part	Description	Std. qty.	Need
1	Separator housing	fiberglass, \varnothing 1200	1	
2	Inlet/outlet sewer	DN110	2	
3	Maintenance shaft	\varnothing 600, height as needed	1	
4	Level alarm device		1	
5	Top cover	plastic	1	
		cast iron		

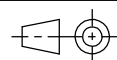

Weight

Date

22.01.2021

Drawn by E. Väljaots

Drawing no. KPR.01.01



Klaasplast OÜ
reg.kood: 11862070
tel: +372 5691 1914
info@mahuti.ee
www.mahuti.ee

Title

Grease separator tank

Sheet
1/1

Scale
1 : 20

Article no.

NS1